



FLEXI-WALL



**SLIDING-STACKING
DOOR SYSTEM SS-100**

SLIDING-STACKING DOOR SYSTEM SS-100

MADE TO MEASURE OPTIONS, SAFE OPERATION, BETTER USER COMFORT

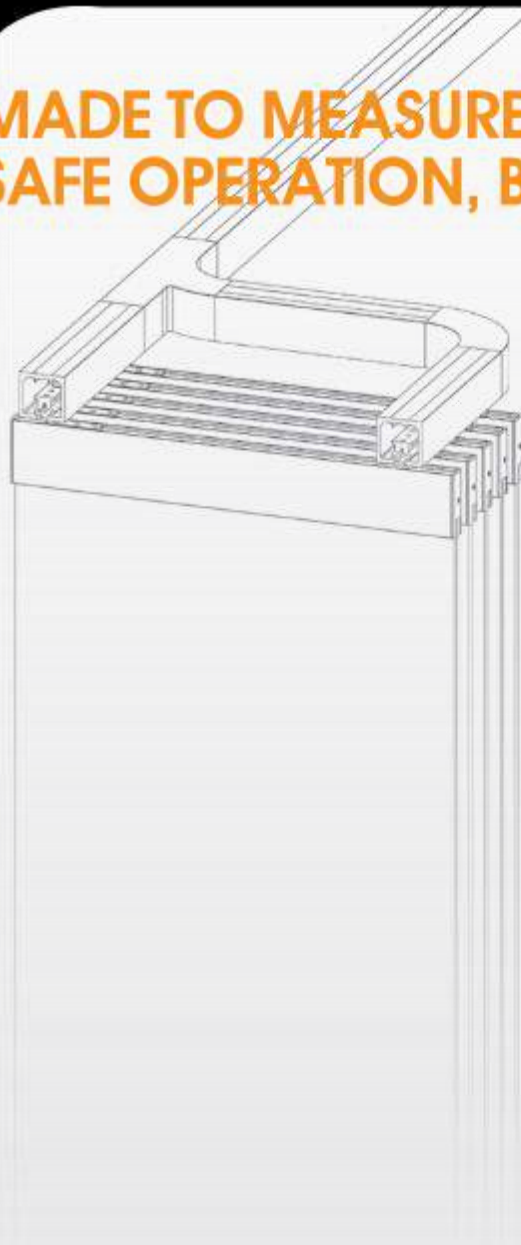

Flexi-wall Sliding-Stacking Door system is an aluminium track and hanger system which transports semi-frame glass panels and aluminium framed doors through 45, 90, 135 degree switches for closing off big opening areas by stacking the panels or doors. The advantage of this system is that there is no need to use a floor guide or channel guide on the floor. The only visible parts are the top and bottom door rails, so that even when the system is closed, it presents a clean, attractive, transparent frontage. Therefore the product is ideally suited for shop fronts, hotels, convention centers, corporate offices and private houses.



SLIDING-STACKING DOOR SYSTEM SS-100

TYPICAL INSTALLATION

Flexi-wall sliding-stacking door systems are made up of the following components:

- Top Track for direct mounting to a steel girder or similar on the ceiling.
- Top and bottom rails composed of base rail, clip on covers and end caps, which are clamped onto the toughened glass panels.
- Roller, carriers, and carrier profiles which ensure that the panels sliding easily with minimum effort.
- Stacking areas, in which the sliding panels are neatly and compactly stacked when the door is opened.

Door DIMENSION

Max. Panel Height: up to 3600mm

Max. Panel Width: up to 1100mm

Optimal Panel size for easy sliding approx: 800mm x 2500mm

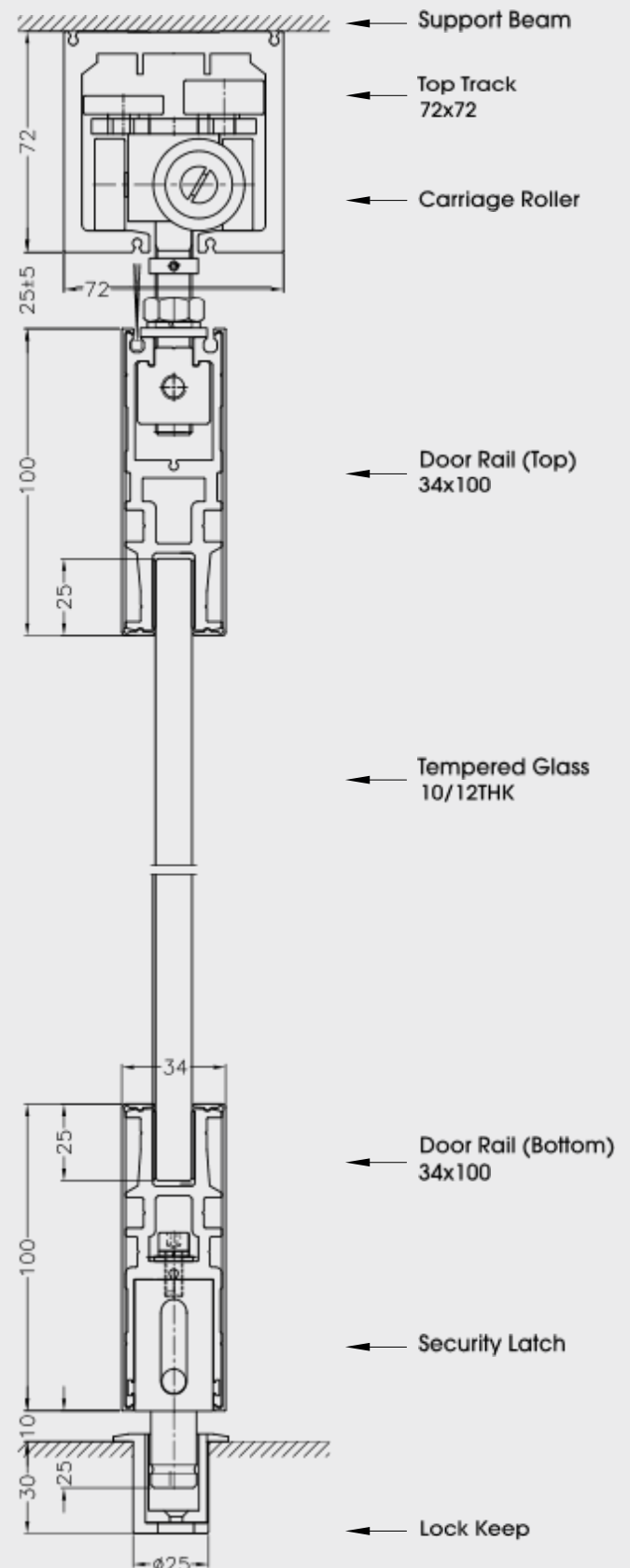

SLIDING-STACKING DOOR SYSTEM SS-100

STACKING LAYOUT

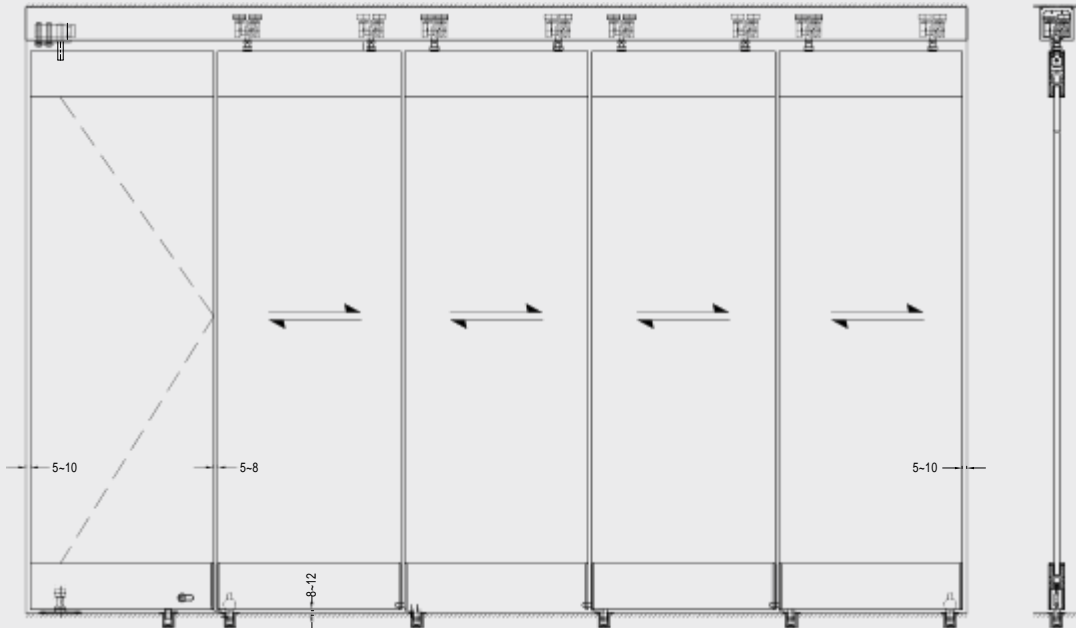

Most popular stacking layout, where the end panel might be a swing door.

1. Swing door (end panel)
2. Sliding panel
3. Stacking area (when the system is opened, sliding panels can be arranged to sliding to the left or to right)

TYPICAL PARKING CONFIGURATION

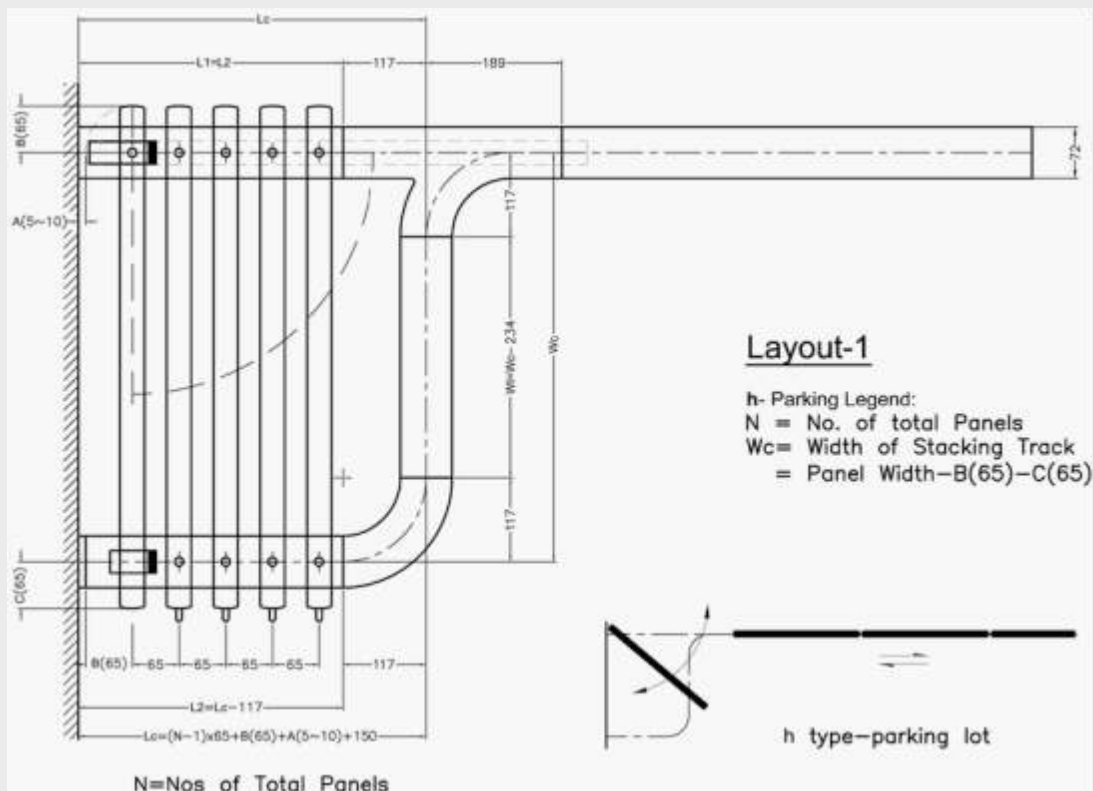

SLIDING-STACKING DOOR SYSTEM SS-100

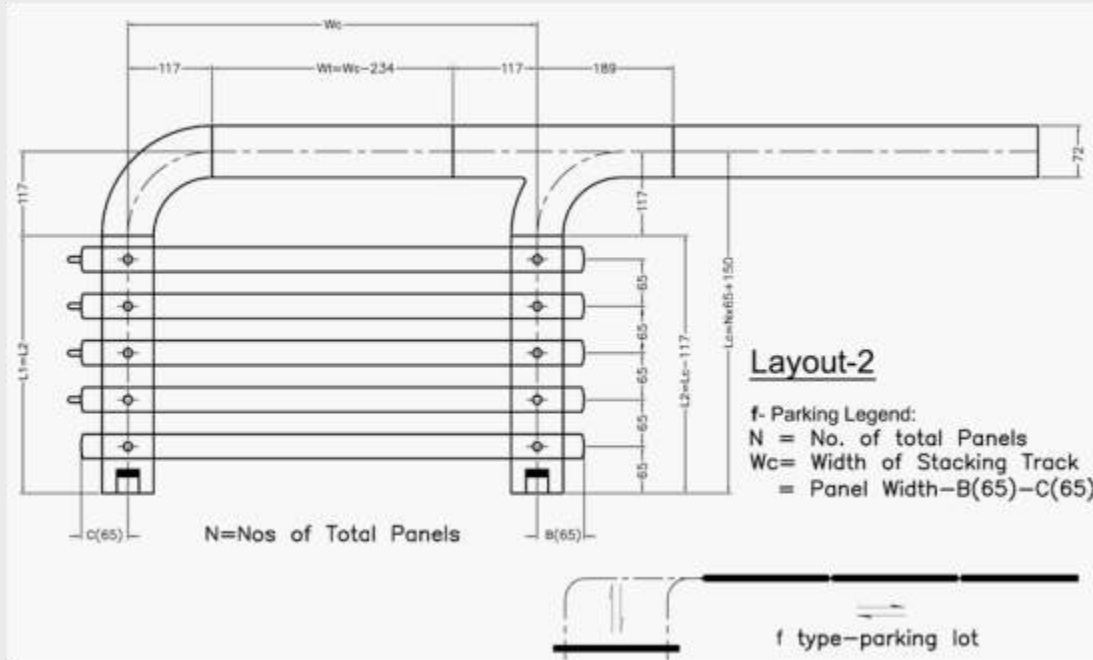

CROSS SECTION

Sliding Panel
c/w security latch

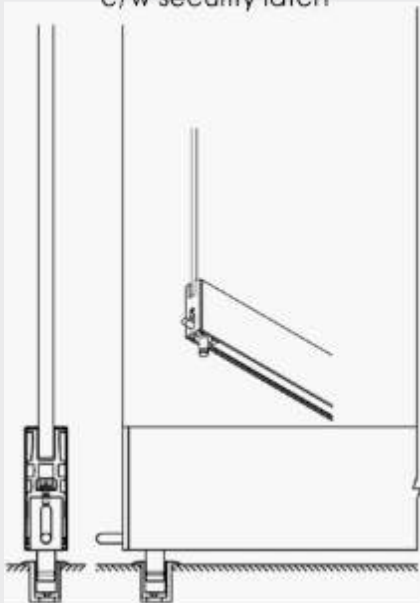

Sliding Panel c/w
Thumb Push latch

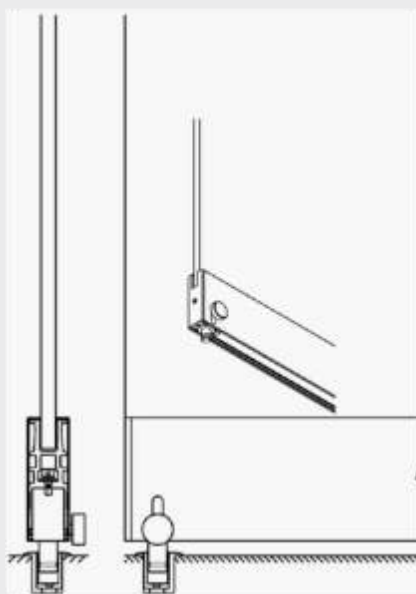

Sliding/Swing Panel
c/w Lockset

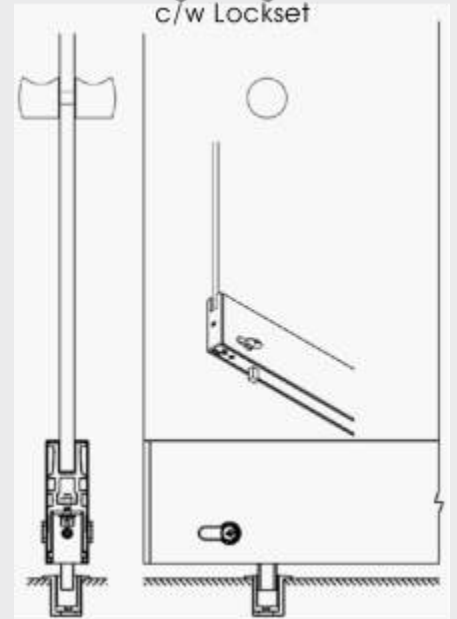

SLIDING-STACKING DOOR SYSTEM SS-100

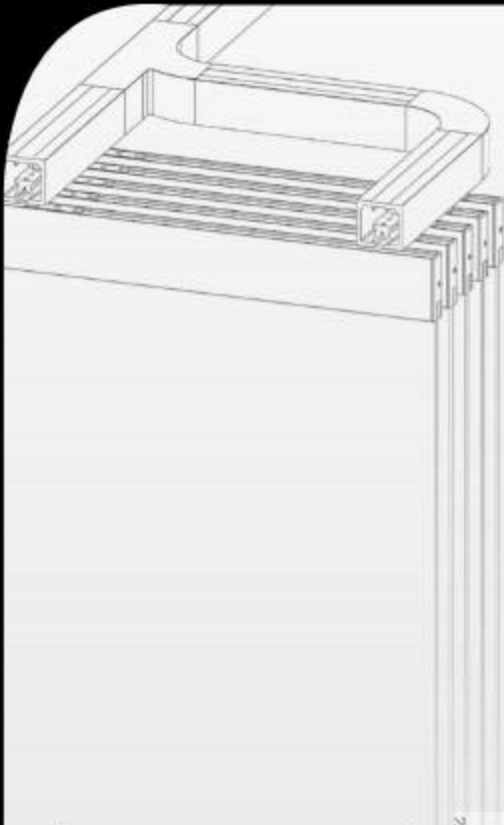

ALUMINIUM TOP TRACK

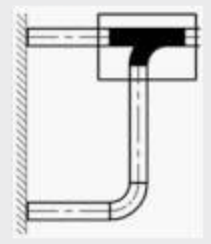
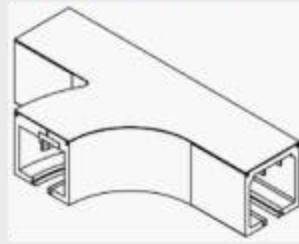

DWG-A

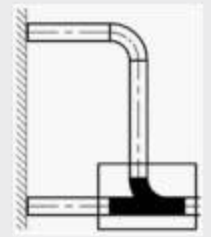
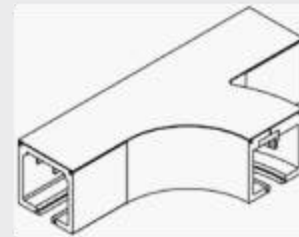

DWG-B

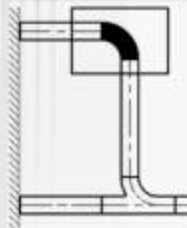
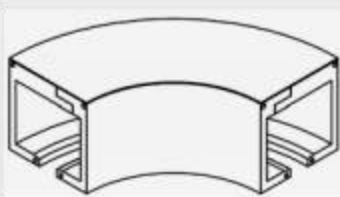

DWG-C

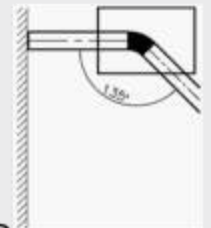

DWG-D

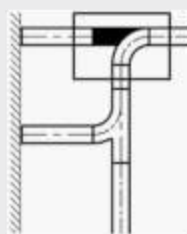
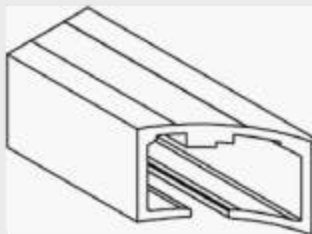

DWG-E

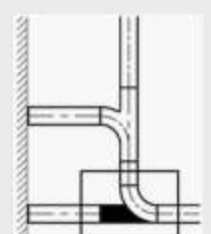
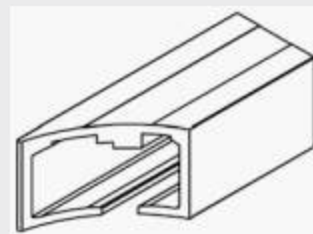

DWG-F

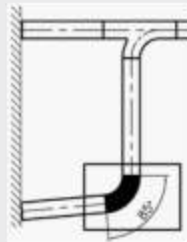
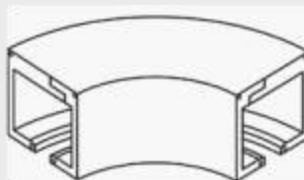

DWG-G

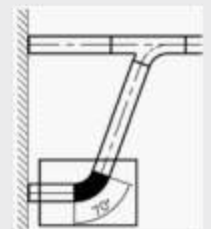
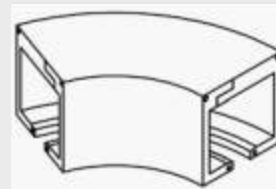

DWG-H

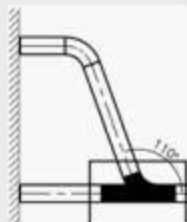
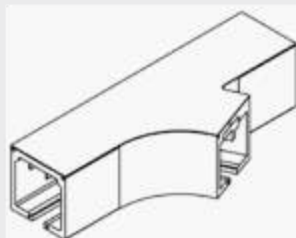

DWG-I

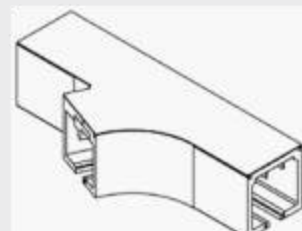

DWG-J

SLIDING-STACKING DOOR SYSTEM SS-100

ACCESSORIES

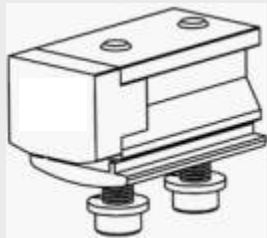

Stopper



End Cap 3



End Cap 2



End Cap 1

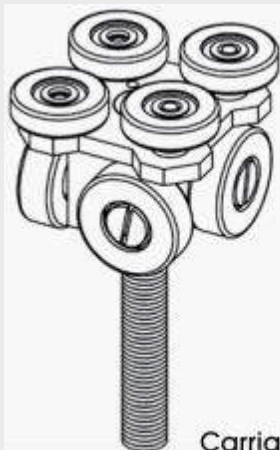

Carriage Roller

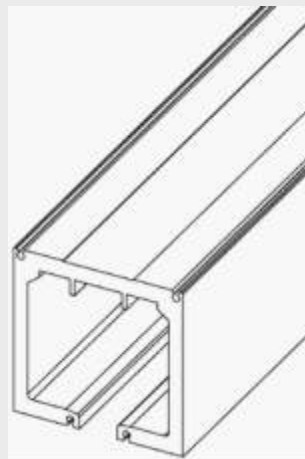

Running Track

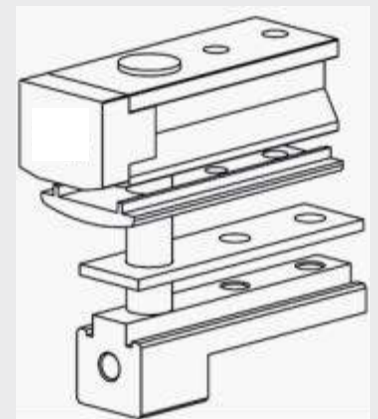

Top Pivot

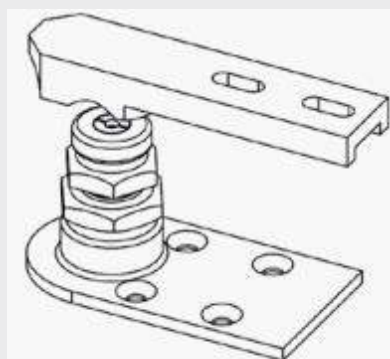

Floor Pivot

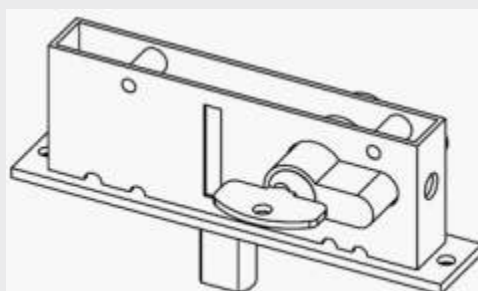

Lock Set

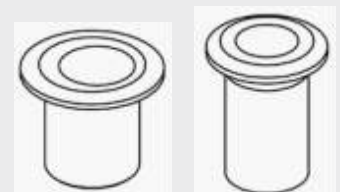

Bolt Keeper

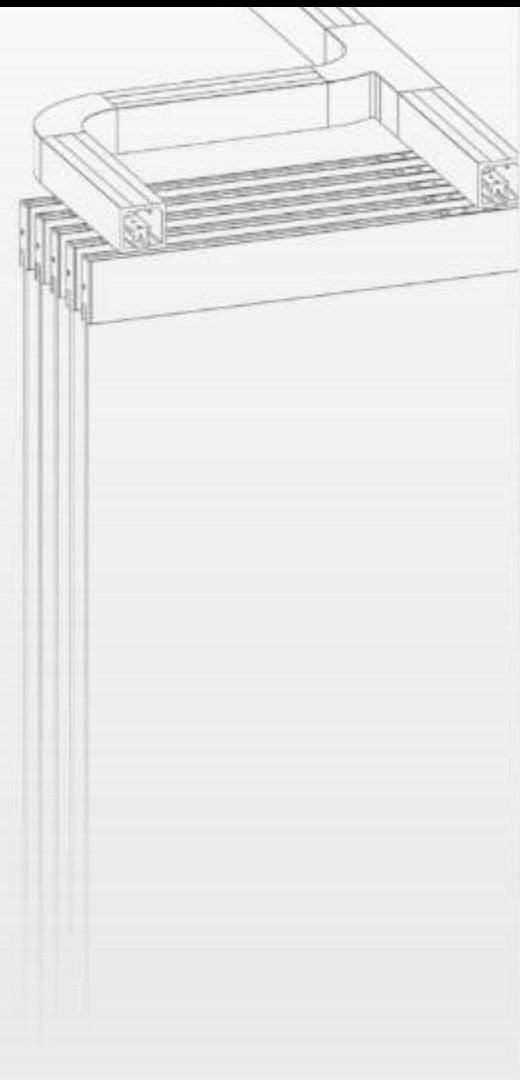



FLEXIWALL MARKETING SDN BHD

(867612-H)

1st Floor, Lot 32602-B, Jalan 1/45A,
Batu 5, Jalan Ipoh, Taman Kok Lian,
52100 Kuala Lumpur, Malaysia.

Tel : +603-6258 7737 Fax : +603-6242 7727

Email : flexiwallmarketing@hotmail.com